



# EXCALIBUR®

TIE-SHEET DISPENSER

## EXTENDED | 800 MONO | DUO | QUATTRO

*PAPER SHEETER TO BE INTEGRATED INTO PALLETIZING LINE  
WITH TROLLEY  
& CUSTOMIZED TABLE-LENGTH TO BRING THE TIE-SHEET TO THE ROBOT*

*Stand-alone or driven-mode sheeting of 1200x800 mm sheets  
Half- and quarter-sheets versions*

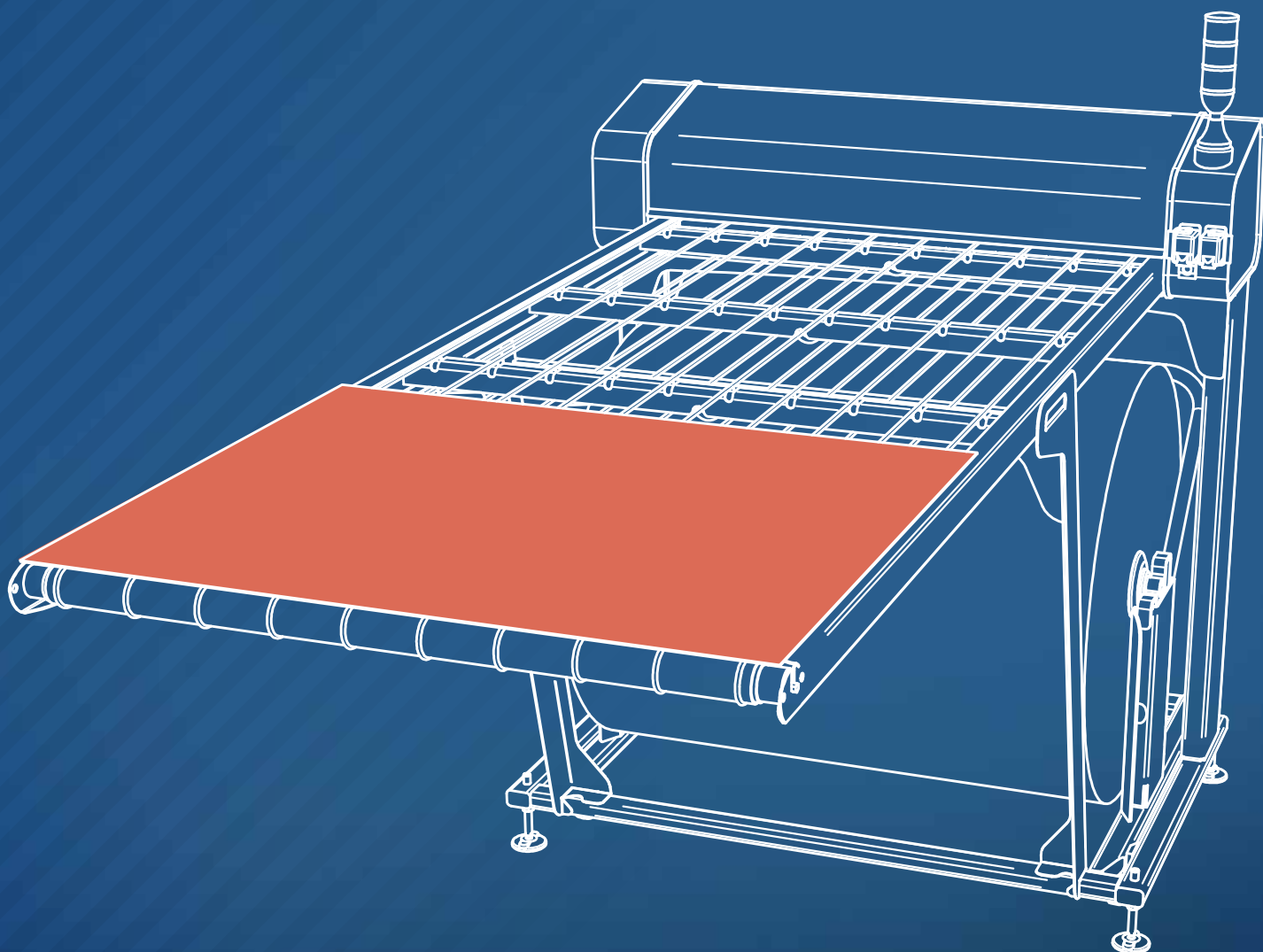

# MODEL EXTENDED | 800

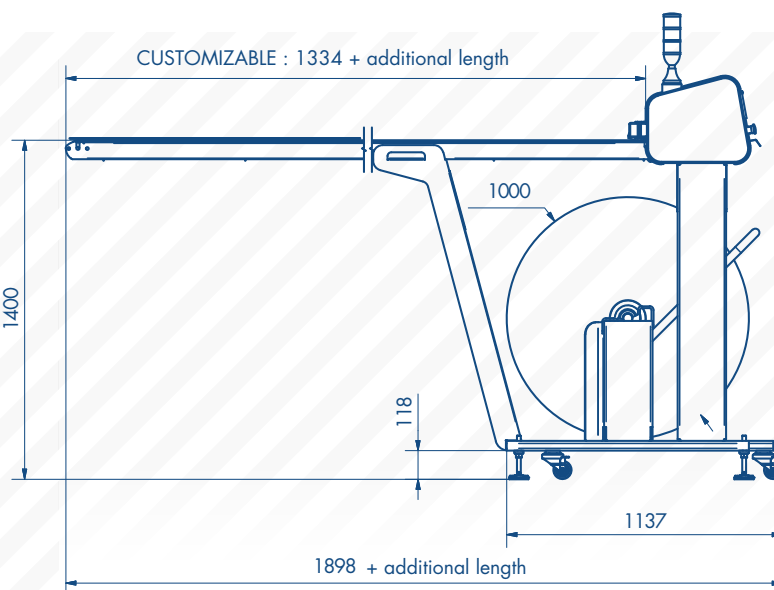
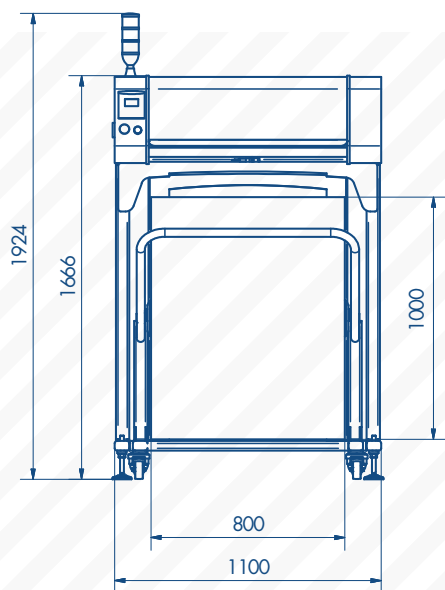

## VERSION MONO

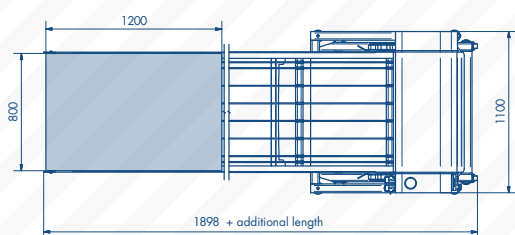

## VERSION DUO

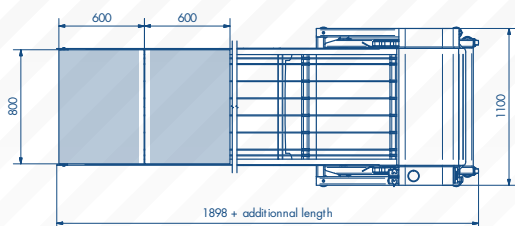

## VERSION QUATTRO

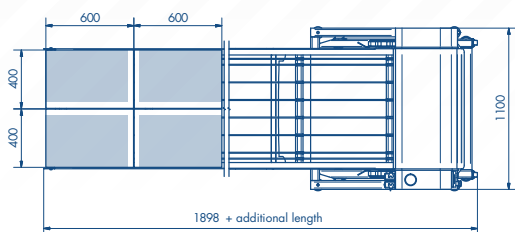

## TECHNICAL SPECIFICATIONS

Roll width	800
Roll diameter	1000 mm
Sheeting length	From 600 mm to 1220 mm
Cutting accuracy	± 1 mm
Number of sheets	MONO : 1 DUO : 1 or 2 QUATTRO : 1, 2 or 4
Data base	15 pre-programmed references
Tie-sheet position	Centered or Sheet edge
Position accuracy	± 1 mm
Paper type	From 60 to 300 g/m <sup>2</sup> Kraft & anti-slip paper
Through-put speed	6 sheets / minute
Operating mode	Stand-alone or driven-mode
Power supply	115V / 230V~50-60 Hz
Guarantee	500 000 cuts or 12 months
Knife lifetime	500 000 cuts
Counter-knife lifetime	500 000 cuts
Roll holder trolley	To simplify and anticipate roll changeover
Roll monitoring	Continuous monitoring of roll diameter with operator alarm
Long-life tooling	High hardness steel of the knife & counter-knife
HMI Access control	2 access levels (100 % customizable)



Health & safety conformity :  
Directive 2006/42/CE  
(Normes EN 12100/EN 14121)



TECHNICOAT  
*Solution*

solution@cgp-coating.com - www.cgp-coating.com

