



# NASTRO-SB AQUA™

the professional solution  
for sustainable packaging



SEMI-AUTOMATIC CASE SEALER

# NASTRO-SB AQUA™ UNIFORM TB



## UNIFORM FORMAT CASE SEALER FOR WATER ACTIVATED TAPE

For years, water-activated tape has resurged due to its effectiveness in package protection and its alignment with sustainability, recyclability, and superior performance.

Today's Water activated tape excels because it's recyclable with cardboard and offers exceptional adhesion, adapting to various temperatures and supporting heavy packages. Its strong adherence to cardboard also makes it tamper-resistant, enhancing security.

However, transitioning to this technology has been challenging, as users have had to rely on mostly manual and ergonomically poor dispensers.



SIAT, a leader in advancing packaging technologies to support customer growth, introduces Nastro-SB Aqua a new case sealing system that combines automation with sustainability. Nastro-SB Aqua replaces manual dispensers with an automated solution, enhancing both sustainability and performance.

Available on the Nastro-SB platform, Nastro-SB Aqua applies both reinforced and non-reinforced water-activated tapes quickly and ergonomically. The Nastro-SB Aqua range includes models for only bottom sealing, fixed formats, and random sizes.

**The NASTRO-SB AQUA solution finally automates the previously manual process of applying water-activated gummed tape. SIAT's solution integrates seamlessly into a company focused on delivering durable machines with a very low total cost of ownership, while also increasing productivity, reducing environmental impact, and ensuring enhanced performance. No one can match the reliability and longevity of SIAT's taping machines.**

## FEATURES & BENEFITS

### From Manual to Automated Process:

- The automated solution to replace manual operations with a table dispenser, significantly increasing productivity (up to **10 boxes/min**) and improving ergonomics (eliminating the need for manual tape handling).
- Easy and ergonomic tape reel changeover and threading for seamless operation.
- Intuitive HMI for fast setup and simple control, combined with clear diagnostic features to streamline operations.

### Driver of Sustainability:

- Flexible solution capable of using both Reinforced and Non-Reinforced Water Activated tapes, reducing plastic use and promoting sustainability.
- Able to perform in cold environments with an automatic heating system, ensuring energy-efficient operation even in challenging conditions.
- Designed for easy cleaning and maintenance, ensuring a longer product lifecycle and reducing waste.

### Superior Performance with Anti-Tamper Tape:

- Capable of sealing a wide range of box sizes, up to 650mm in width, with adjustable tape legs from 50 to 70mm, ensuring secure closure and tamper-evidence.
- Precise pneumatic management of tape pressure on boxes, adapting to various tape qualities and ensuring optimal sealing every time.
- Enhanced security with the use of anti-tamper Water Activated tapes, offering superior performance in box sealing.

|  |                                      |
|--|--------------------------------------|
| BOX ADJUST   | Manual                               |
| POWER SUPPLY   | 220/240V1PH-400V3PH(50/60Hz+N)       |
| OPERATING TEMPERATURE  | +5°C / +40°C                         |
| TAPING UNIT TECHNOLOGY   | Pneumatic                            |
| TAPE REEL max diam. (mm)   | 410                                  |
| TAPE REEL core (mm)  | 70 - 76                              |
| TAPE width (mm)  | 50 - 80                              |
| TAPE leg (mm)  | 50 - 70                              |
| TOP & BOTTOM UNITS   | YES                                  |
| BELT SPEED   | 3 speed (max 23 m/min.)              |
| MAX SPEED PERFORMANCE (according to box length, box filling, box quality and operator performance) | 10 bpm                               |
| BELT POSITION  | Side                                 |
| BOX L MIN-MAX (mm)   | 150 - INF.                           |
| BOX W MIN-MAX (mm)   | 150 - 650                            |
| BOX H MIN-MAX (mm)   | 130 - 500                            |
| Water Storage TOP UNIT (lt.)   | 1                                    |
| Water Storage BOTTOM UNIT (lt.)  | 1                                    |
| TYPE OF WAT PROCESSABLE (both vegetable & animal glue)*  | STD > 70 gr. + Reinforced            |
| HMI  | Color Touch Screen Display 2,8 inch. |
| AQUA LOGIC FEATURES  | Pause Mode                           |
|  | Threading Mode                       |
|  | Unit Diagnostics                     |
|  | Tape leg set up                      |
|  | Temperature set up                   |
| OTHER FEATURES   | Easy Bottom Reel change              |
|  | Precise adjustment of taping rollers |
|  | Missing tape feeding/End Tape        |
|  | Beacon                               |
|  | Counters on handles                  |

## TOP UNIT

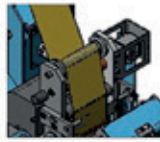
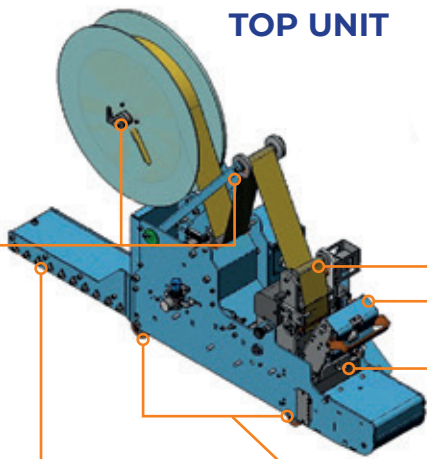

Econdenser for tape length management

Top opening for easy access and easy tape threading

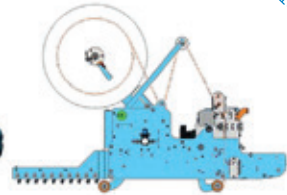
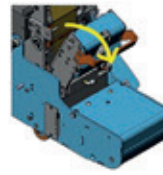

Easy water cartridge replacement

Automatic heat and water supply control for best adhesive activation

Perfect pneumatic management of tape pressure on boxes to adapt on various consumables qualities

Adjustable outfeed wiping system for excellent tape adhesion

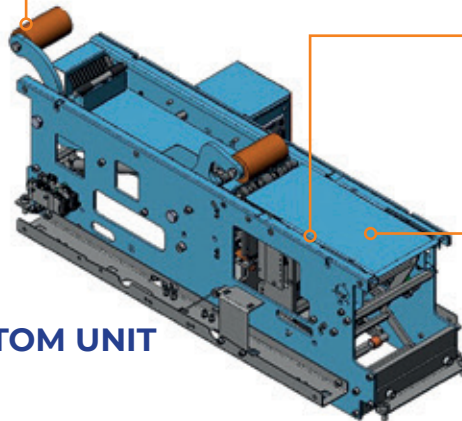
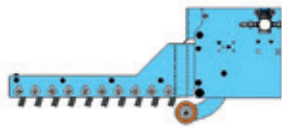

Adjustable tape roller support and roller guides + dancer for stable tape unwinding and feeding

## BOTTOM UNIT

Bottom unit opening for easy access, tape threading and water cartridge replacement

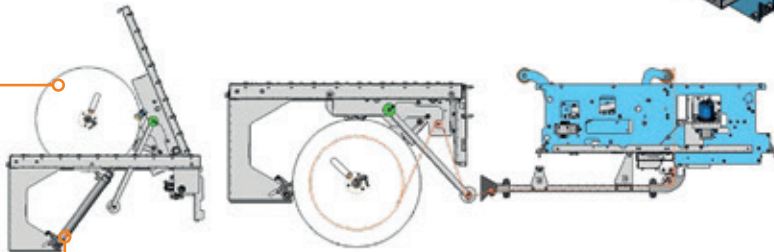
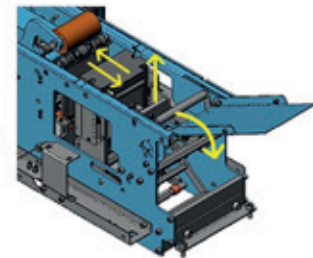

Pneumatic outfeed bench for easy and ergonomic reel replacement

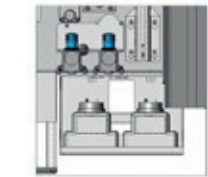

2 liters storage refillable with tap water



Counters on handles



Intuitive touchscreen HMI with full control and diagnostic in few clicks

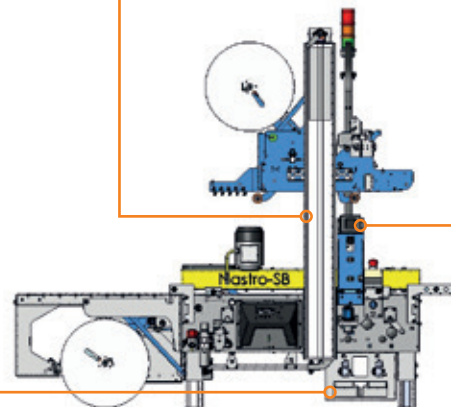
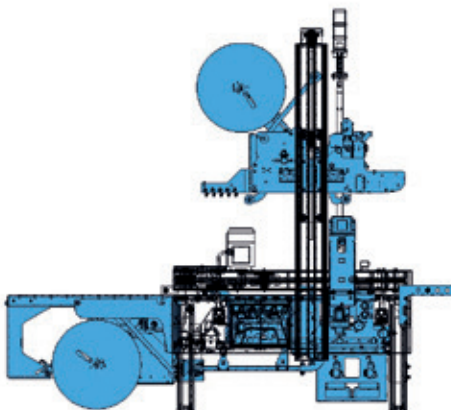



## The SIAT Group



Headquartered in Northern Italy, SIAT is established as a quality leader in end-of-line industrial packaging solutions, specializing in taping, strapping and wrapping machines, as well as flexographic printing machines.

Based in Ohio (USA), Combi is a Northern American producer of industrial packaging systems, engineering and manufacturing case erectors, tray formers, case sealers, case packers, robotic packaging systems, and ergonomic monoblock hand-packing stations.



Located in Northern Italy, Tam has been producing small metal parts and providing precision machining services for over 30 years.

For over 50 years, we have been manufacturing high-tech equipment and are proud to be recognized by our customers as among the leading brands in packaging machinery and components. Our solutions are utilized across various industries, including food and beverage, e-commerce, logistics, packaging, and consumer products.

## Our machines are designed to:



### Increase customer productivity

Our machines boast an average life of 25 years, while our customers pay off their investment in only 4 to 5 months.

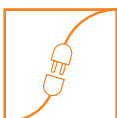

### Total lower cost of ownership

Our machines are designed for easy maintenance and simple installation. They are developed to be user-friendly and durable, while also being easy to integrate and manage.



### Reduce environmental impact

We strongly believe in pursuing this goal through our environmental approach, envisioning the future of packaging as a collaborative effort with our customers to find the most sustainable and secure solutions. Each machine is designed to consume less energy, minimize material usage, and reduce waste.



### Be connected

Thanks to Optirun, the SIAT Group's IoT solutions brand, we can calculate tape and box consumption, monitor film usage, and track all machine parameters to prevent downtime.



### E-commerce

Buy directly at [www.shop.siat.com](http://www.shop.siat.com)



### Service

Contact our field service Team at [servicenow@siat.com](mailto:servicenow@siat.com)



Via Puecher 22,  
22078 Turate - Como  
[www.siat.com](http://www.siat.com)

